

CUSTOMER PART No.

CUSTOMER

CAN ART STD.

DIE No.

EH05247

DESCRIPTION

2.000" O.D. x 0.095" THK. ROUND TUBE

PROPOSAL No.

H-1887

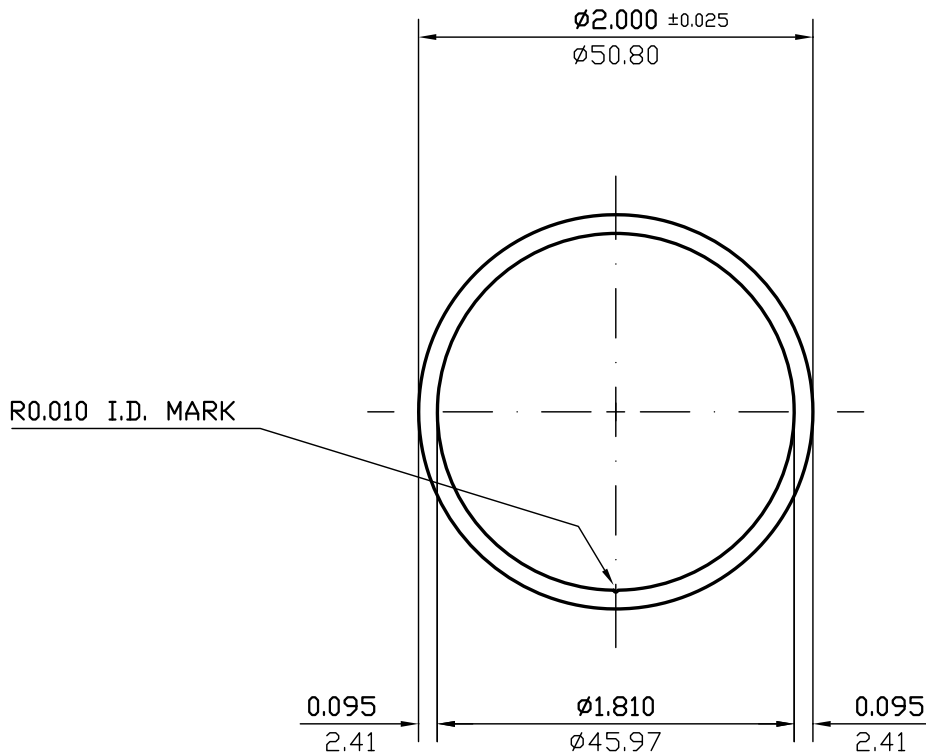

WALL THICKNESS 0.095 (2.41) EXCEPT AS SHOWN

DATE	REV	DESCRIPTION	BY		
03/10/23	2	REMOVED EXPOSED SURFACES AND ALLOY	JASON		
08/06/99	1	REDRAWN	P.M.		
EST.AREA	0.568	IN. ²	EST.AREA	367	MM. ²
EST.WT.	0.671	LBS/FT.	EST.WT.	0.998	KG/M.
EST.PER.	11.981	IN.	EST.PER.	304.3	MM.
OUT PER.	6.283	IN.	OUT PER.	159.6	MM.
C.C.D.	2.000	IN.	C.C.D.	51	MM.
FACTOR	18	FINISH	M/F	ALLOY & TEMP.	
CKD BY		SCALE	1:1	DWN BY	G.M. DATE 03/04/91

CAN ART

ALUMINUM EXTRUSION INC.

85 PARKSHORE DRIVE
BRAMPTON, ONT L6T 5M1
TEL. NO. (905) 791-1464
FAX NO. (905) 791-9151
E-MAIL: canart@canart.com

THIS DRAWING IS NOT NECESSARILY A COPY OF YOUR ORIGINAL. PLEASE APPROVE DIMENSIONS AND TOLERANCES INDICATED. CAN ART ASSUMES NO RESPONSIBILITY EITHER TECHNICAL OR LEGAL FOR HAVING THIS SHAPE MADE. THE CUSTOMER AGREES TO FULLY PROTECT CAN ART ALUMINUM FROM CLAIMS OF OTHERS RESULTING FROM THIS SHAPE.

SIGNED: _____ DATE: _____

NOTE: BREAK ALL CORNERS WITH 0.015" (.38 MM) RADIUS UNLESS OTHERWISE NOTED. STANDARD TOLERANCES TO APPLY UNLESS OTHERWISE SPECIFIED.